

ALUMINIUM SAW BENCH

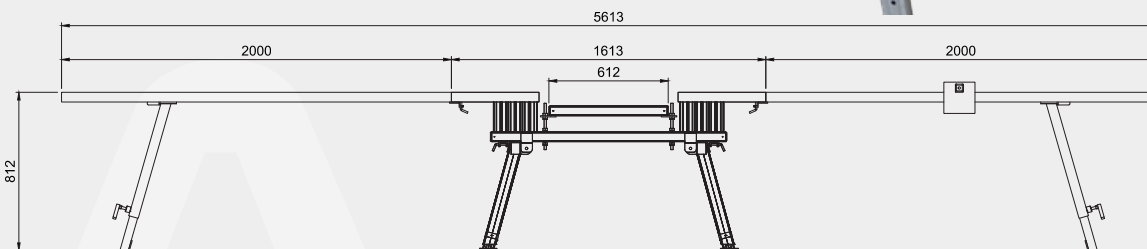
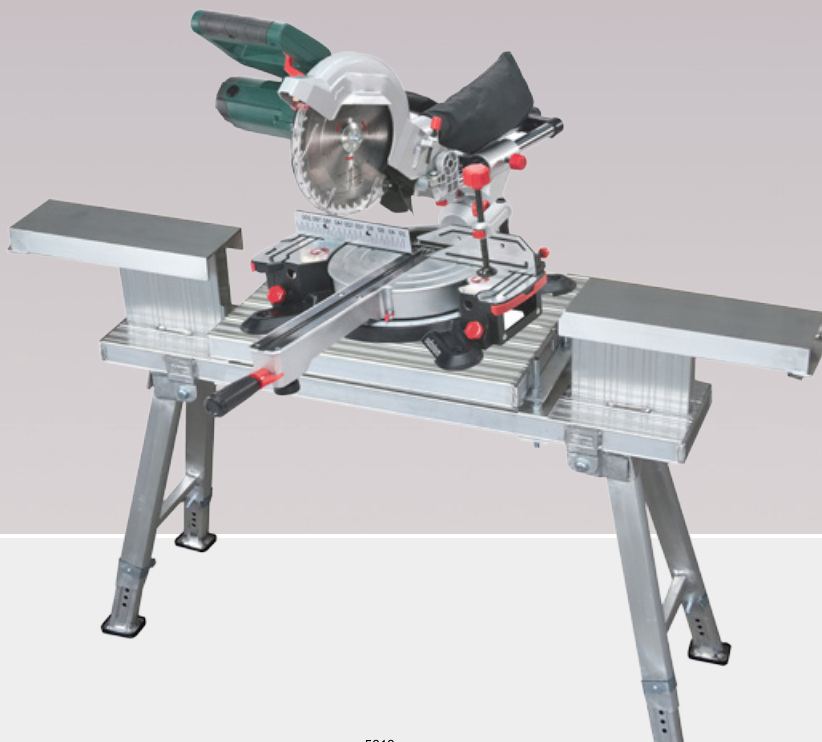

FEATURES

- Heavy duty product with lightweight aluminium construction.
- Quick to set up & dismantle
- Easy maintenance
- Height adjustable legs
- Fully compatible for all types of drop saws
- Fast, interchangeable mechanisms when changing saws

- Designed & manufactured in Australia

SPECIFICATIONS

- Width 450 mm
- Length - up to 5.7 m in length (2 m x Extensions either side + 1.7 m Bench)